

## PRODUCT CODE:

**T-3MSS-HMSTB**

Stainless Steel Hob Mounted Infrared Sensor Tap. Battery Powered. WELS 6 Star 4L/Min. 50 Deg Maximum Operating Temperature. 500kPa Recommended Working Pressure

**T-3MSS-HMSTB-TV**

S/S Hob Mounted Infrared Sensor Tap with Tempering Valve. Battery Powered. WELS 6 Star 4L/Min. 50 Deg Maximum Operating Temperature. 500kPa Recommended Working Pressure

**T-3MSS-HMSTM**

Stainless Steel Hob Mounted Infrared Sensor Tap. Mains Operated. WELS 6 Star 4L/Min. 50 Deg Maximum Operating Temperature. 500kPa Recommended Working Pressure

**T-3MSS-HMSTM-TV**

S/S Hob Mounted Infrared Sensor Tap with Tempering Valve. Mains Operated. WELS 6 Star 4L/Min. 50 Deg Maximum Operating Temperature. 500kPa Recommended Working Pressure

## FEATURES &amp; BENEFITS:

- Working pressure: 30kPa - 500kPa
- Maximum water temperature: 50°C
- Sensor range nominal: 50mm - 200mm
- Maximum run time: 60 seconds
- Mains powered or Battery powered - 6V transformer or 2x CR123 3V Lithium Batteries
- WELS 6 Star 4L/Min

**GUARDIAN™  
TAPWARE**

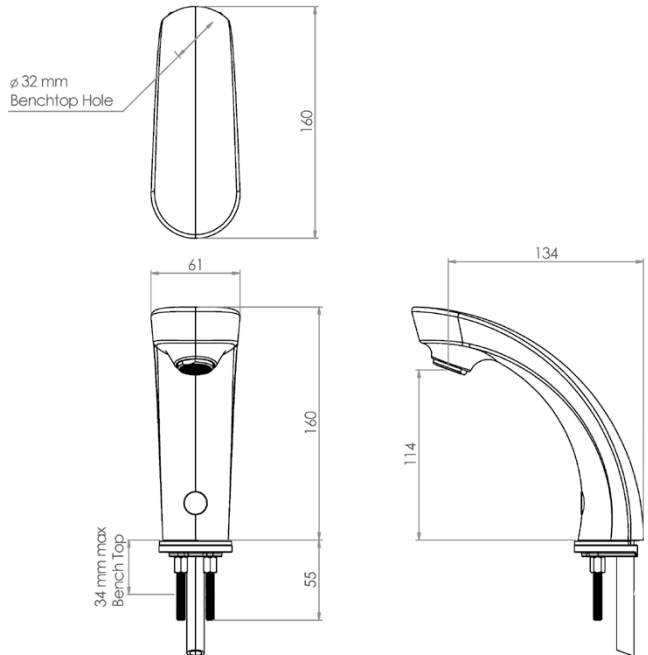

Details accurate at time of print. Whilst all care has been taken in compiling this information, designs & dimensions shown are indicative only and should not be relied upon without prior approval.

**3monkeez**®

STAINLESS STEEL EVOLUTIONS  
Innovate · Create · Deliver